

GENERAL ARRANGEMENT PLAN

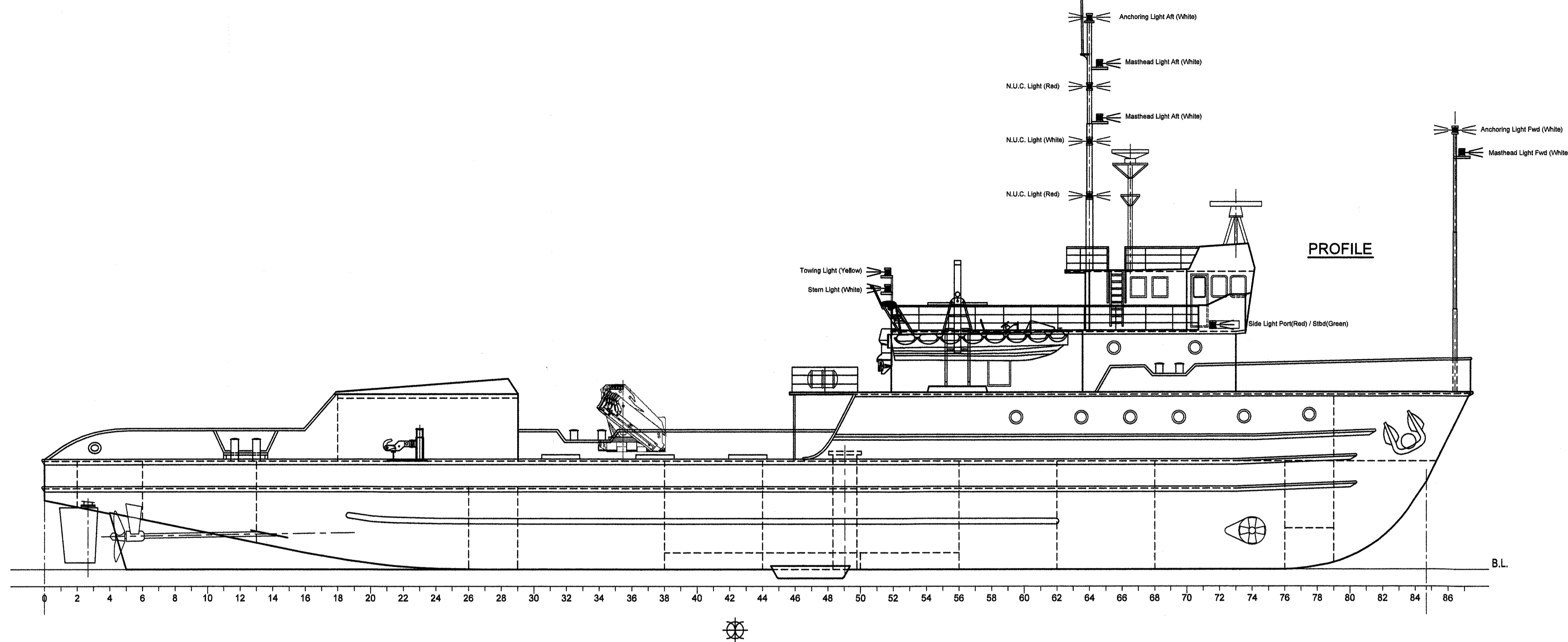

WHEEL HOUSE TOP

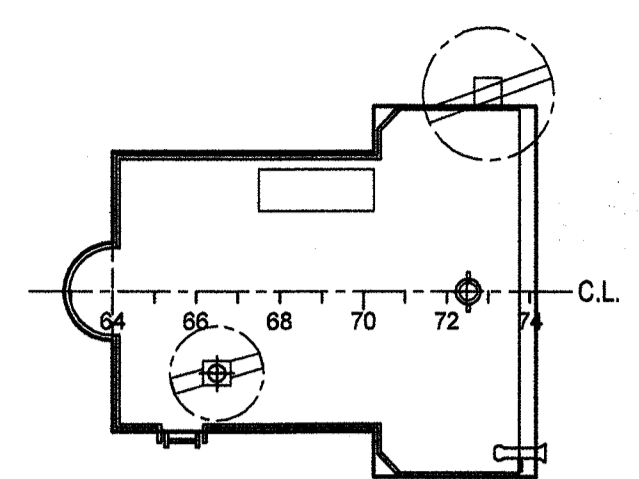

BRIDGE DECK

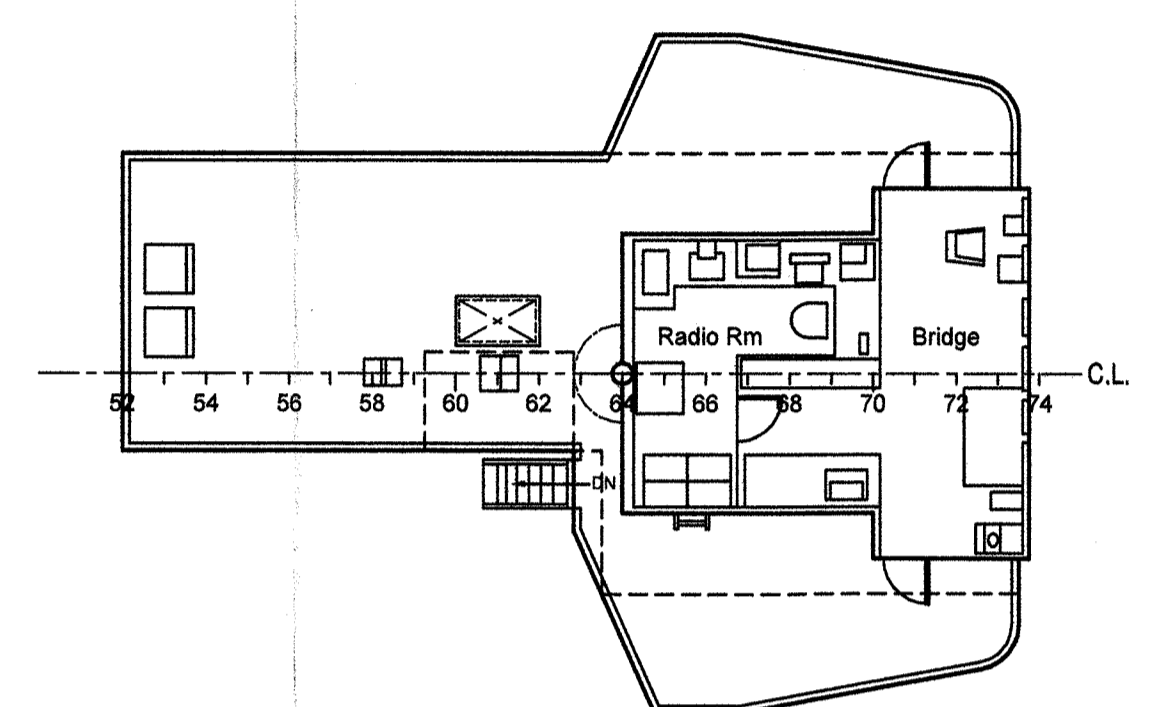

MAIN DECK

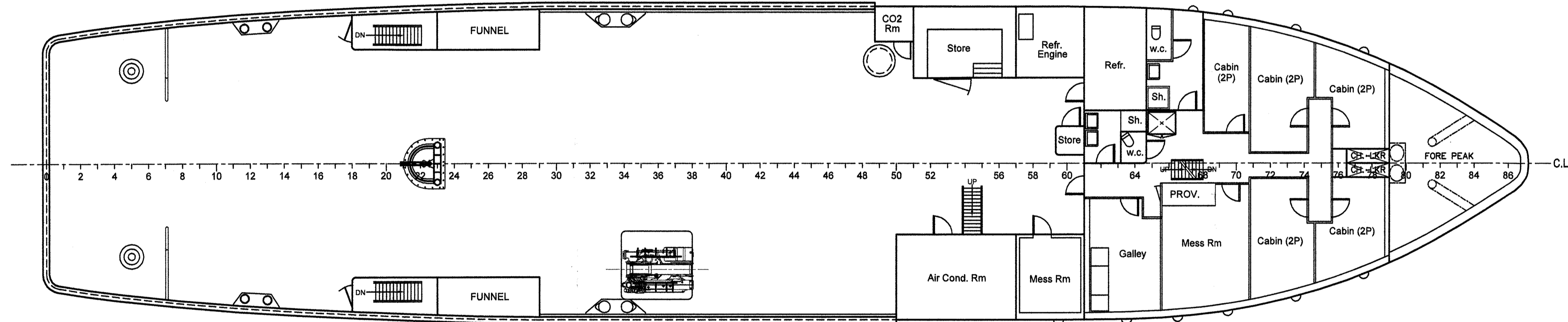

BOAT DECK

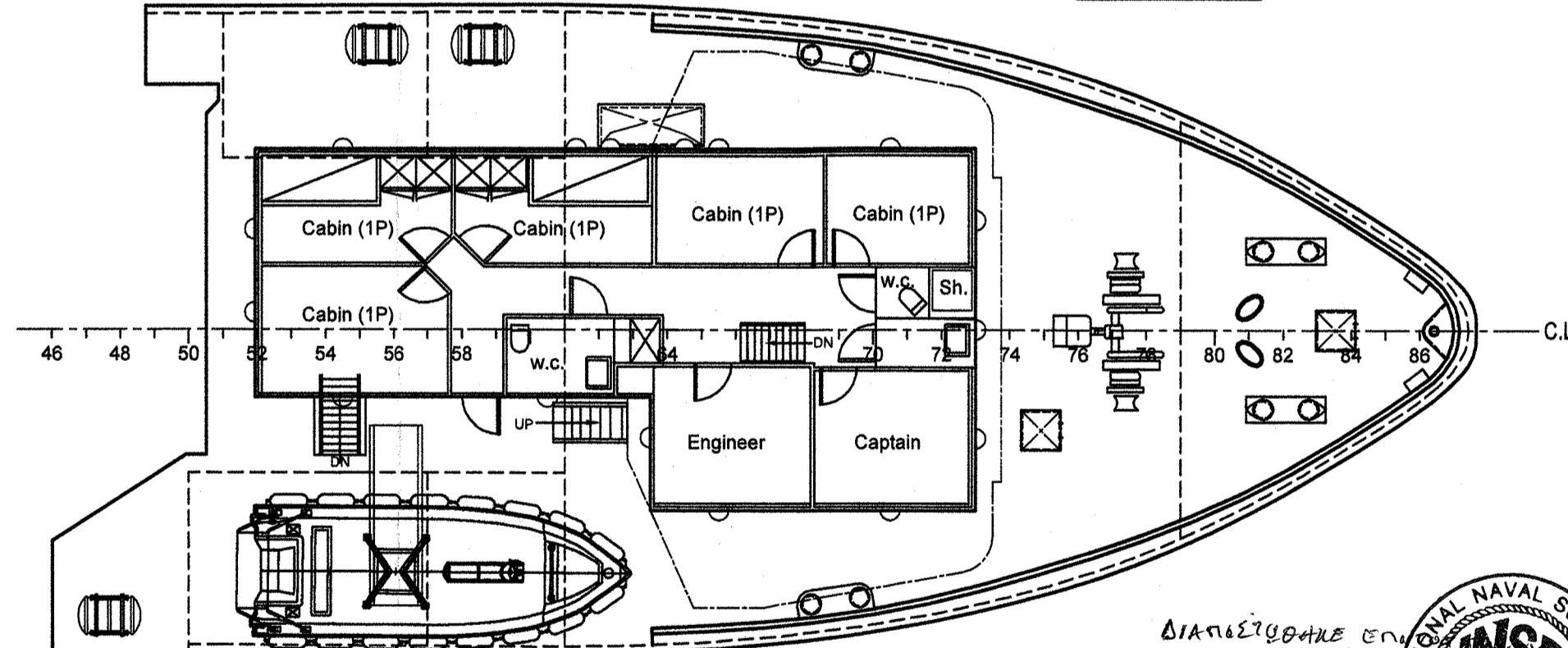

LOWER VIEW

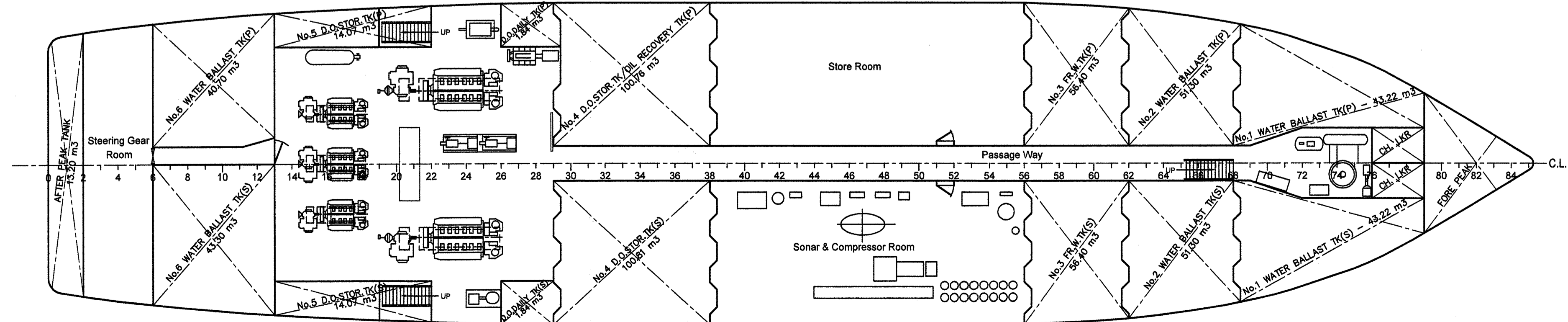

PRINCIPAL DIMENSIONS

Length O.A.	52.85 m
Length B.P.	49.20 m
Length (calc.)	50.80 m
Breadth(mld)	11.00 m
Depth to Main Dk(mld)	3.95 m
Draft (ext)	3.35 m
Frame Scacing	0.60 m
Year of Build	1967
Year of Conversion	1978 / 2015

AS FITTED

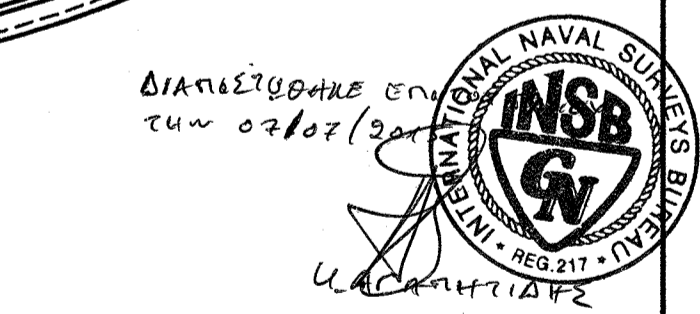

ΑΠΟΤΟΜΟΓΡΑΦΙΚΟ ΝΤΑΞΙΟΣ
ΔΙΑΓΡΑΜΜΑΤΟΣ ΜΑΝΩΤΗΣ ΜΗΧ/ΤΟΣ ΜΗΧ/ΚΟΣ
Α. Μ. Σ. Ε. 2 8 3 8 8
Α.Φ.Μ.: 116 458307 Α. ΠΕΡΙΣΤΕΡΙΟΥ
ΘΕΜΙΣΤΟΚΛΕΟΥΣ 269 - ΠΕΡΙΣΤΕΡΙ 12134
Τ.Η. 55 74 3 5 1 2 1 5

NEW HELLENIC SHIPYARDS S.A.		4	
Kato Pounta, Ampelakia		3	
16602, Salamina - Greece		2	
Tel: +30 210 4670224-4674555, 4677590		1	Increase of total Diesel Oil Tanks' Capacity
Fax: +30 210 4620864		A/A	Revisions
e-mail: info@spanopoulos-group.com			January 2013
www.spanopoulos-group.com			Date:
Vessel's Name: Tug "CHRISTOS XXXII" - IMO No. 6724713			
Cad / Cam by:	Date:	Title:	Project Number:
N.H.A.	July 2015		T 160
Checked by:	Date:	GENERAL ARRANGEMENT PLAN	
N.H.A.	July 2015	Drawing Number: 0415-160-01	
		Scale: 1:100	

GLOBAL COPYRIGHT © THIS DRAWING IS CONFIDENTIAL AND MUST NOT BE COPIED, REPRODUCED ELECTRONICALLY, ALTERED, STORED OR UTILISED IN ANY WAY OR EXHIBITED TO ANY THIRD PARTY, WITHOUT THE WRITTEN PERMISSION OF NEW HELLENIC SHIPYARDS S.A.